



4" HMI



6" HMI



8" HMI



10" HMI

## HMI Operator Interfaces

### Safety Information

Carefully note and observe the following safety precautions when receiving, inspecting, installing, operating, maintaining and troubleshooting. The following words, WARNING AND CAUTION, are used to mark safety precautions when using the Eaton product. Failure to observe these precautions may void the warranty!

#### Installation

##### ⚠ WARNING

- Comply with instructions for installation. Otherwise it may cause equipment damage.
- Do not install the product in a location that is outside the stated specification for the device. Failure to observe this caution may result in electric shock, fire or personal injury.

#### Wiring

##### ⚠ WARNING

- Connect the ground terminals to a class-3 ground (ground resistance should not exceed 100Ω). Improper grounding may result in electric shock or fire.

#### Operation

##### ⚠ CAUTION

- HMI users should use HMIsoft to perform editing. Using HMI without HMIsoft may result in abnormal operation.

##### ⚠ CAUTION

- Do not modify wiring during operation. Otherwise it may result in electric shock or personal injury.
- Never use a hard or pointed object to hit or strike the screen as doing this may damage the screen, causing HMI to work abnormally.

#### Maintenance and Inspection

##### ⚠ CAUTION

- Do not touch any internal or exposed parts of the device as electrical shock may result.
- Do not remove operation panel while power is on. Otherwise electrical shock may result.
- Wait at least 10 seconds after power has been removed before touching any terminals or performing any wiring and/or inspection as an electrical charge with hazardous voltages may still remain in the unit even after power has been removed.
- Turn the power off before changing backup battery and check system settings after finishing the change (all data will be cleared after changing the battery).
- Be sure the ventilation holes are not obstructed during operation, or malfunction may result.

#### Wiring Method

##### ⚠ CAUTION

- Remove the terminal block from the HMI before wiring.
- Insert only one wire into one terminal on the terminal block.
- If the wiring is in error, perform the wiring again with proper tools. Never use force to remove the terminals or wires, or malfunction or damage may result.

#### Communication Wiring

##### ⚠ CAUTION

- Comply with communication wiring specification for wiring.
- Wiring length should comply with the stated specification for HMI.
- Ensure proper grounding to avoid bad communication quality.

### General Description

Positioned between the ELC graphics panels and the ePro series of operator interfaces, HMI is the work horse of the industry. All units feature a touchscreen and function keys to suit all environments and applications. They range in screen size and color to fit available space and application needs. All units offer RS-232, RS-485 and RS-422 communications.

- True analog touchscreen
- Real time trending
- Alarming and alarm storage
- Event storage (History)
- USB for data storage
- Add I/O
- Multi-language
- Auto-scale application from 10 – 4"
- Off-line simulation
- Retentive internal data storage
- Trend stored data
- USB for screen data transfer
- USB printer
- Macro programming
- Recipe storage
- On-line simulation
- 8 level password protection

### Accessories (sold Separately)

The following accessories could help improve your HMI experience.

- ELC-CBPCELCE — 3 meter cable to connect between the HMI and Eaton Logic Controller (ELC)
- ELC-CBPCELC1 — 1 meter cable to connect between the HMI and Eaton Logic Controller (ELC)
- HMIEC0806 — 8 In DC, 6 Relay Outputs expansion module
- HMIEC1612 — 16 In DC, 12 Relay Outputs expansion module
- HMIECENT Ethernet expansion card. Modbus TCP, upload and download
- ELC-PS01 — 1 amp 24V DC power supply
- ELC-PS02 — 2 amp 24V DC power supply

## 1 Unpack and Inspect

Included with the HMI are:

- Panel Mounting clips (number of clips varies depending on the size of the unit).
- DB9 gender changer for easy connection to the Eaton Logic Controller (ELC).
- 3-pin power 24V DC connector.

## 2 Available Communication Ports

4" HMI

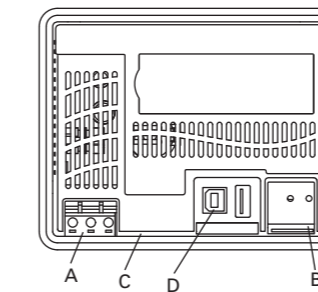

A	Power input terminal
B	Expansion slot
C	COM 1
D	USB

6" HMI

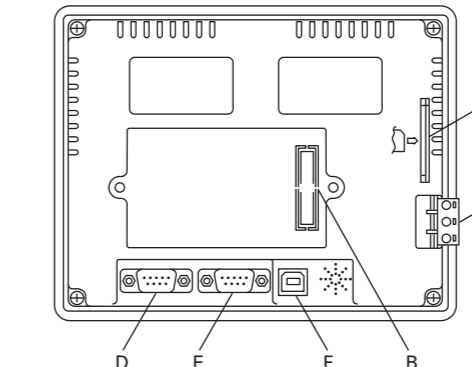

A	Power input terminal
B	Expansion slot
C	Memory card
D	COM 2
E	COM 1
F	USB
G	Battery cover

8" HMI

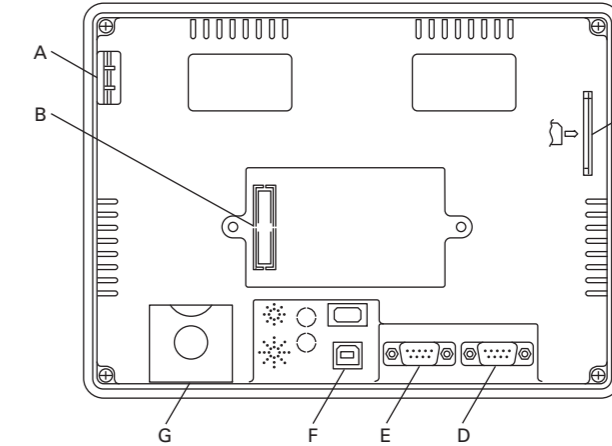

A	Power input terminal
B	Expansion slot
C	Memory card
D	COM 2
E	COM 1
F	USB
G	Battery cover

10" HMI

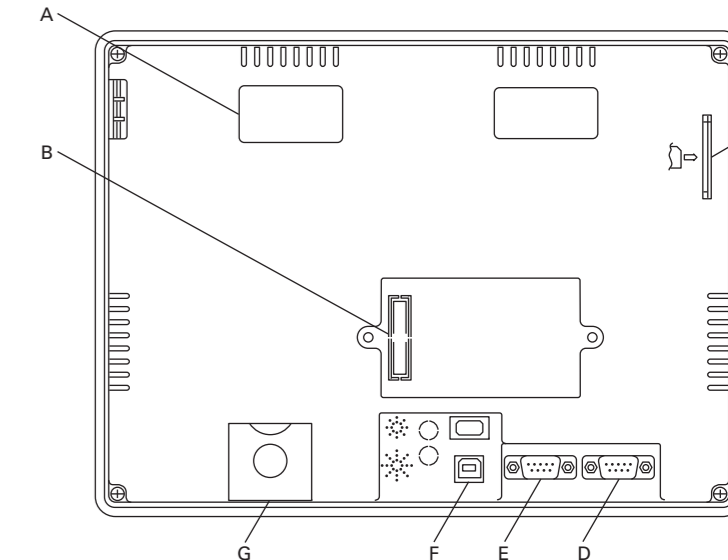

A	Power input terminal
B	Expansion slot
C	Memory card
D	COM 2
E	COM 1
F	USB
G	Battery cover

For 4" HMI Only

COM1 and COM3 are RS-232 Only

PIN	COM1 Not Used		COM3 Used	
	COM1	COM3	COM1	COM3
1				
2	RX		RX	
3	TX		TX	
4				
5	GND		GND	GND
6				
7	RTS			TX
8	CTS			RX
9				

Note: Blank = No connection.

COM2

PIN	COM2 Pinout for RS-422 & RS-485	
	RS-422	RS-485
G	GND	GND
T+	TX+	TX+
T-	TX-	TX-
R+	RX+	RX+
R-	RX-	RX-

Note: Blank = No connection.  
Note: For RS-485 Connect TX+ to RX+ and TX- to RX-.

For 6", 8" and 10" HMI Only

COM1 is RS-232 Only

PIN	COM1 RS-232	
	COM1	
1		
2	RX	
3	TX	
4		
5	GND	
6		
7	RTS	
8	CTS	
9		

Note: Blank = No connection.

COM2 and COM3

PIN	DB 9 Pinout for COM2 and COM3						
	RS-232			RS-485		RS-422	
	COM3 Not Used	COM3 Used	COM3 Used	COM2 Not Used	COM3 Used	COM3 Not Used	COM3 Used
1							
2	RX			RX-	RX+	RX-	RX+
3	TX			TX	TX+	TX+	TX+
4					TX-	TX-	TX-
5	GND			GND	GND	GND	GND
6					TX-	RTS-	TX-
7	RTS				TX+	RTS+	TX+
8	CTS				RX+	CTS+	RX+
9					RX-	CTS-	RX-

Note: Blank = No connection.  
Note: For RS-485 Connect TX+ to RX+ and TX- to RX-.

### 3 Connect Touch Panel to Computer

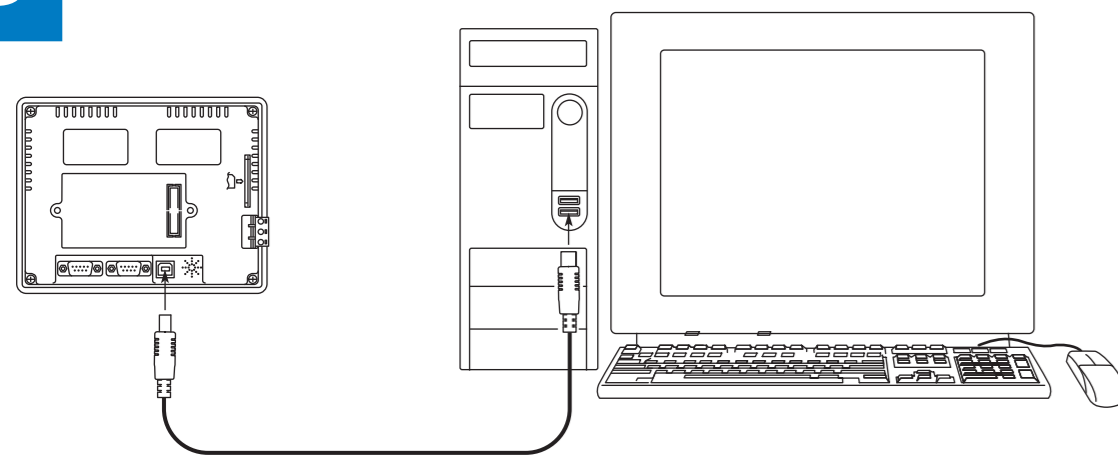

### 4 Provide Power to the Touch Panel

Recommended wiring is in the table below:

Type	Wire Gauge	Stripped Length	Torque
Solid	28-12 AWG	7-8 mm	4.5 lb-in
Stranded	28-12 AWG	7-8 mm	4.5 lb-in

Be sure to plug power line into HMI according to following arrow direction.

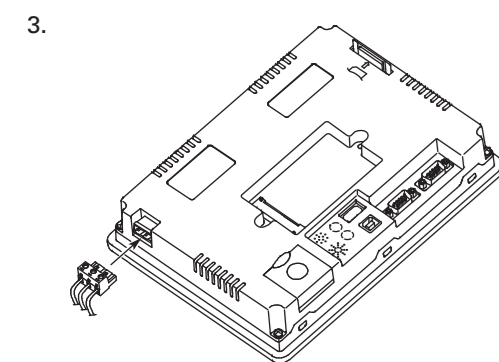
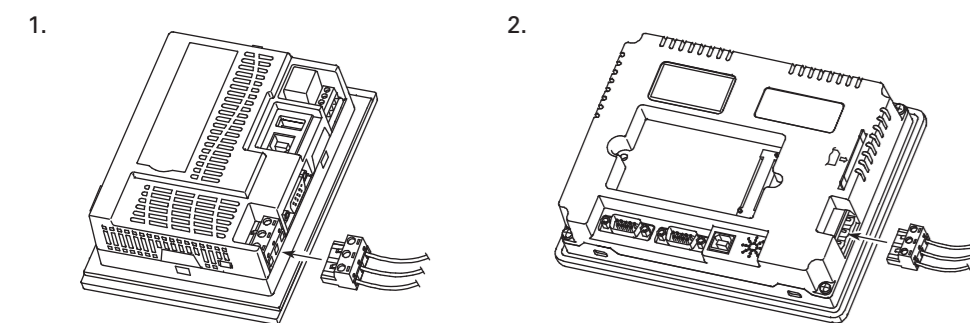

### 5 Accessing the Touch Panel Setup Screens

Press and hold the SYS key for approximately 5 seconds to bring up the System menu. The following can be changed from this menu.

- Date & Time
- Calibrate the touchscreen
- Adjust backlight settings
- Select the download method
- Memory storage management



### Dimensions and Cut-Outs

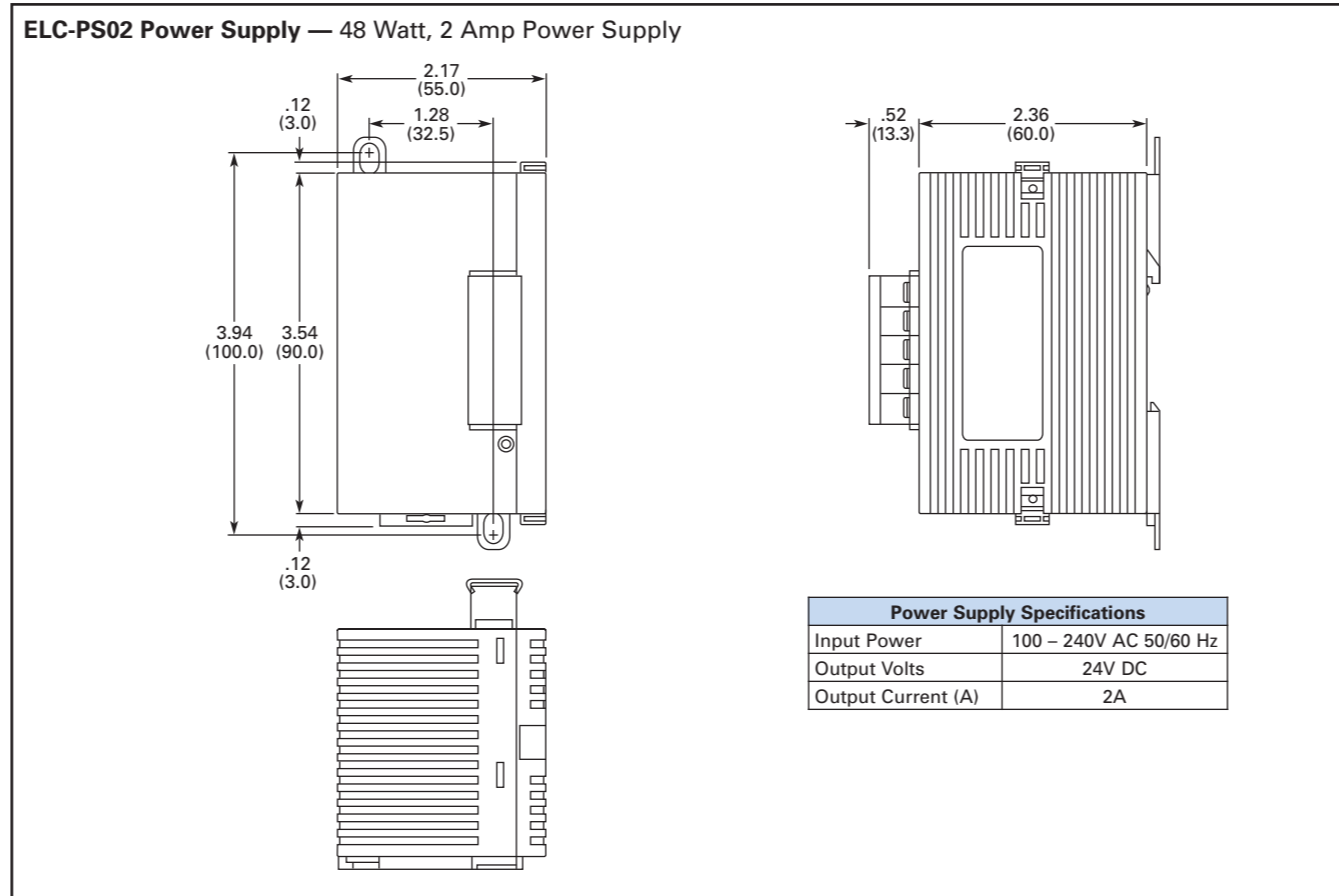
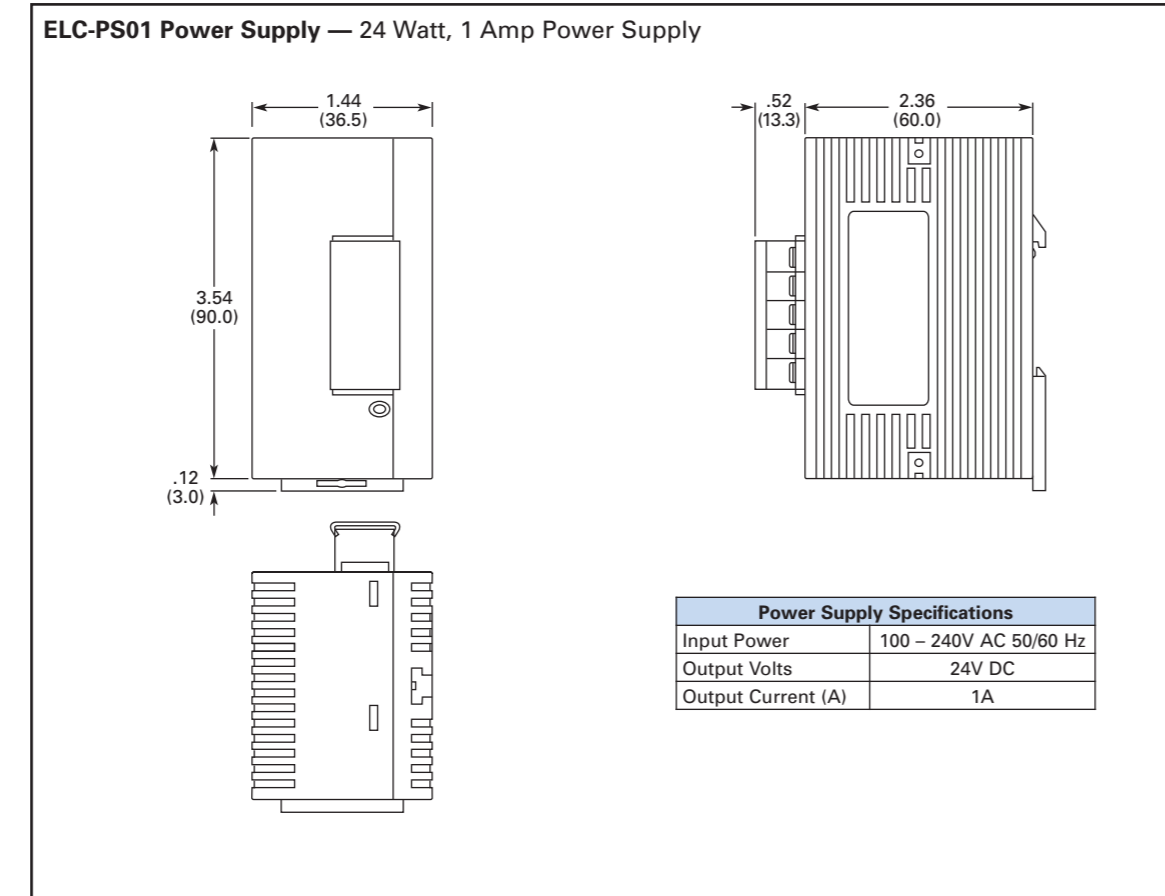
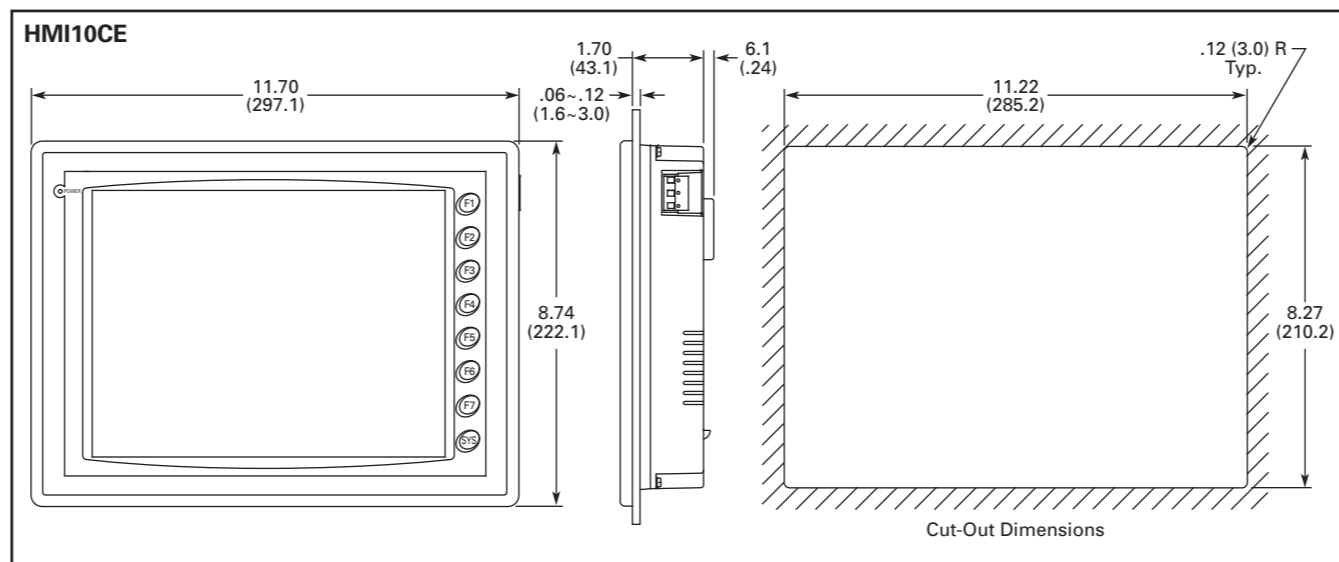
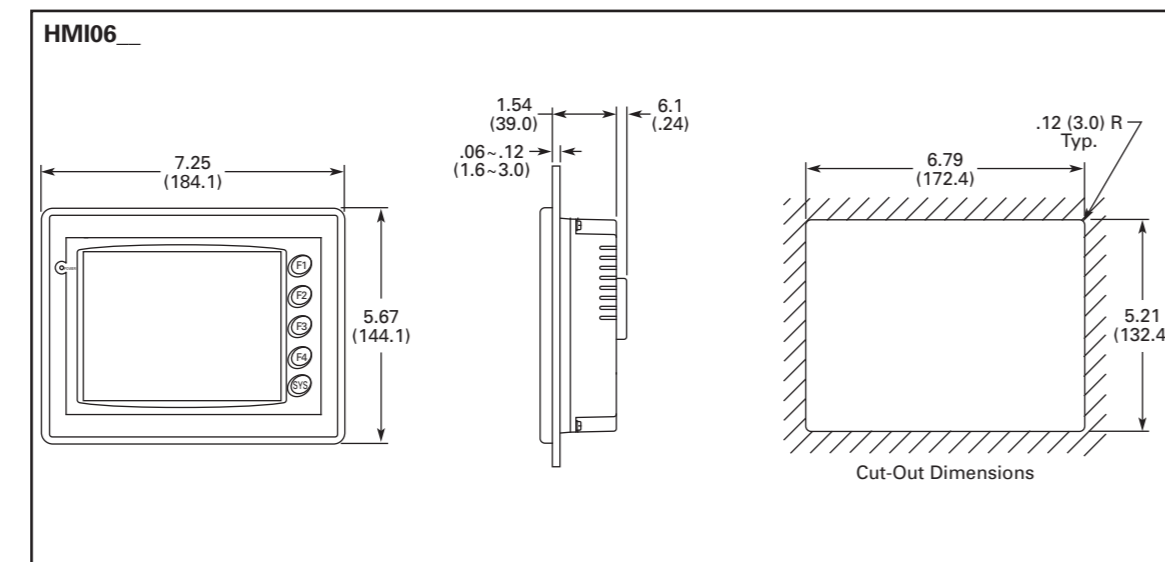
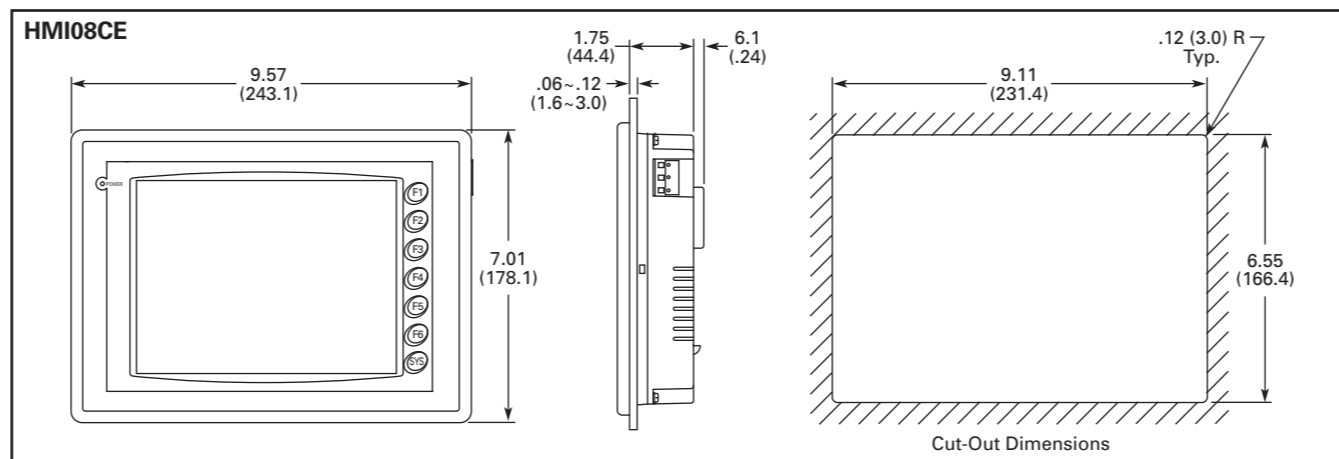
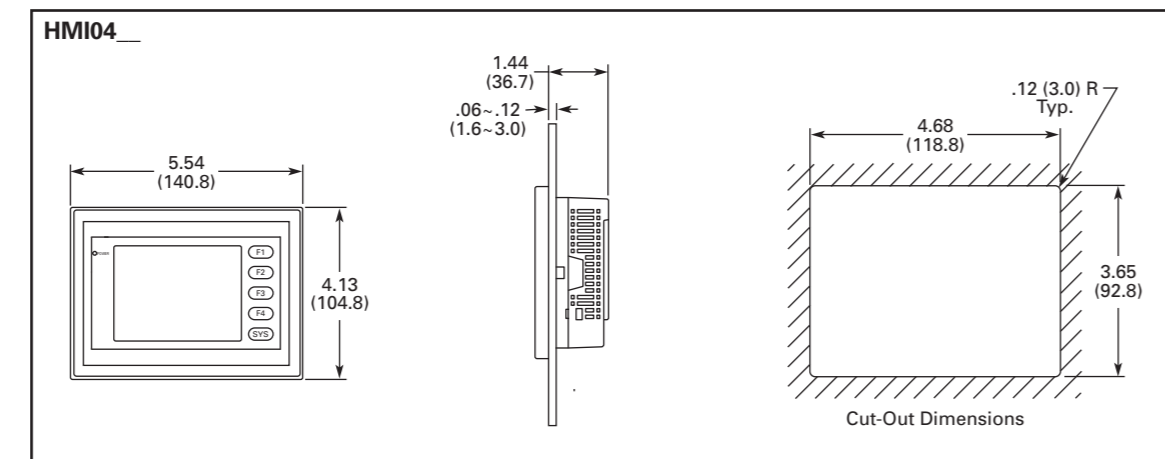

NOTE: Approximate Dimensions in Inches (mm)

### Specifications

Model	HMI04BU	HMI06BE	HMI06GE	HMI06CE	HMI08CE	HMI10CE
Display Type	STN	STN	FSTN	STN	TFT-LCD	
Display Color	8 Blues	8 Blues	16 Grays	256 Colors	65536 Colors	
Screen Pixels	320 x 240 pixels		320 x 240 pixels		640 x 480 pixels	
Back-light Life	About 10,000 hours at 25°C		About 50,000 hours at 25°C		About 50,000 hours at 25°C	About 30,000 hours at 25°C
Display Size	3.8" (78.8 x 59.6 mm)		5.7" (118.2 x 89.4 mm)		8.0" (162.2 x 121.7 mm)	10.4" (215.2 x 162.4 mm)
Operation System	Real Time OS					
MCU	32-bit RISC Micro-controller / 206.4 MHz					
Memory						
Program	1M	3M	3M	3M	7M	7M
History	120K	360K	360K	360K	360K	360K
Recipe	64K ②	128K	128K	128K	128K	128K
Alarm	4K	16K	16K	16K	16K	16K
Data Registers						
Volatile	64K	64K	64K	64K	64K	64K
Non-volatile	1K	1K	1K	1K	1K	1K
Backup Memory (Bytes)	128K		512K		512K	512K
Ext. Memory	SM Card	✓	✓	✓	✓	✓
	USB Disk	✓			✓	✓
Extension Interface	1 Client Ver. 1.1					
USB for Download (USB Client)	✓					
USB for Data Storage / Printer (USB Host)	✓					
LCD Module	LED Back Light	CCFL Back Light	CCFL Back Light	CCFL Back Light	CCFL Back Light	2CCFL Back Light
Function Key	4	4	4	4	6	7
Perpetual Calendar (RTC)	Built-In					
Cooling Method	Natural Air Circulation					
Safety Approval (Waterproof for Front Panel)	IP65 / NEMA 4X / CE / UL / cUL / C-Tick					
Operating Temp.	32° – 122°F (0° – 50°C)					
Storage Temp.	-4° – 140°F (-20° – 60°C)					
Ambient Humidity	10% – 90% RH (0° – 40°C), 10% – 55% RH (41° – 50°C)					
Shock	30G @ 11 ms					
Vibration Resistance	IEC61131-2 compliant When vibration is NOT continuous: 5 Hz – 9 Hz 3.5 mm, 9 Hz – 150 Hz 1G X, Y, Z directions for 10 times					
Dimensions (W) x (H) x (D) in Inches (mm)	5.54 x 4.13 x 1.76 (140.8 x 104.8 x 44.8)	7.25 x 5.67 x 1.85 (184.1 x 144.1 x 47)			9.57 x 7.01 x 2.06 (243.1 x 178.1 x 52.4)	11.70 x 8.74 x 2.01 (297.1 x 222.1 x 51.1)
Weight in Lbs. (kg)	.69 (.315)	1.69 (.768)			2.52 (1.147)	3.79 (1.721)
Backup Battery	3V Lithium Battery CR2032 x 1 / Battery Life: 5 Years					
Buzzer	85dB					
Operation Voltage	DC +24V (10% – 20%) (Please use isolated power supply) ①					
Wattage	2.64	7.2	7.2	7.2	14	15
NIT Rating	100 cd/m <sup>2</sup>	130 cd/m <sup>2</sup>		100 cd/m <sup>2</sup>	400 cd/m <sup>2</sup>	330 cd/m <sup>2</sup>

- ① Please use isolated power supply (not applicable for HMI08CE and HMI10CE).  
② Recipe memory uses program memory.

### Additional Help and Support

For technical support, please contact the Technical Resource Center at 1-800-356-1243, Option 3.

Eaton Corporation  
Electrical Group  
1000 Cherrington Parkway  
Moon Township, PA 15108  
United States  
877-ETN CARE (877-386-2273)  
Eaton.com



PowerChain Management is a trademark of Eaton Corporation. All other trademarks are property of their respective owners.

© 2008 Eaton Corporation  
All Rights Reserved  
Printed in USA  
Publication No. IL04802001E / 27127  
May 2008